

Compact Disc Player

Operating Instructions



CDP-CE375
CDP-CE275

WARNING

To prevent fire or shock hazard, do not expose the unit to rain or moisture.

To avoid electrical shock, do not open the cabinet. Refer servicing to qualified personnel only.

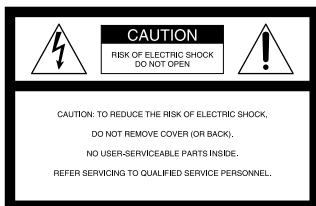

This symbol is intended to alert the user to the presence of uninsulated “dangerous voltage” within the product’s enclosure that may be of sufficient magnitude to constitute a risk of electric shock to persons.



This symbol is intended to alert the user to the presence of important operating and maintenance (servicing) instructions in the literature accompanying the appliance.

INFORMATION

This equipment has been tested and found to comply with the limits for a Class B digital device, pursuant to Part 15 of the FCC Rules. These limits are designed to provide reasonable protection against harmful interference in a residential installation. This equipment generates, uses, and can radiate radio frequency energy and, if not installed and used in accordance with the instructions, may cause harmful interference to radio communications. However, there is no guarantee that interference will not occur in a particular installation. If this equipment does cause harmful interference to radio or television reception, which can be determined by turning the equipment off and on, the user is encouraged to try to correct the interference by one or more of the following measures:

- Reorient or relocate the receiving antenna.
- Increase the separation between the equipment and receiver.
- Connect the equipment into an outlet on a circuit different from that to which the receiver is connected.
- Consult the dealer or an experienced radio/TV technician for help.

CAUTION

You are cautioned that any changes or modification not expressly approved in this manual could void your authority to operate this equipment.

Owner’s Record

The model and serial numbers are located at the rear of the unit.

Record the serial number in the space provided below. Refer to them whenever you call upon your Sony dealer regarding this product.

Model No. _____

Serial No. _____

AC power cord must be changed only at the qualified service shop.

Do not install the appliance in a confined space, such as a bookcase or built-in cabinet.

To prevent fire, do not cover the ventilation of the apparatus with news papers, table-cloths, curtains, etc. And don’t place lighted candles on the apparatus.

To prevent fire or shock hazard, do not place objects filled with liquids, such as vases, on the apparatus.

About this manual

The instructions in this manual are for CDP-CE375 and CDP-CE275. CDP-CE375 is the model used for illustration purposes only. Any difference in operation is clearly indicated in the text, for example, “CDP-CE375 only.”

Tip

Instructions in this manual describe the controls on the player.

You can also use the controls on the remote if they have the same or similar names as those on the player (CDP-CE375 only).

Table of Contents

Parts Identification 4

Front Panel	4
Rear Panel	5
Remote Control	5

Getting Started

Inserting Batteries Into the Remote Control (CDP-CE375 only)	6
Hooking Up the System	6

Playing CDs

Loading the CD	7
Playing the CD — Normal Play/Shuffle Play/Repeat Play	8
Using the CD display	9
Replacing Discs While Playing a Disc	10
Programming the CD tracks	11
Fading In or Out	12

Recording From CDs

Recording a CD by Specifying Tape Length (Time Edit)	12
Adjusting the Recording Level (Peak Search)	13

Additional Information

Precautions	14
Notes on CDs	14
Troubleshooting	15
Specifications	15

Front Panel

The items are arranged in alphabetical order.

Refer to the pages indicated in parentheses () for details.

CDP-CE375

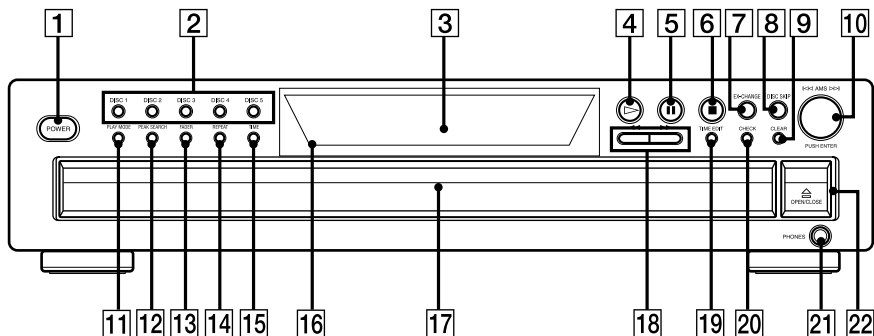

CDP-CE275

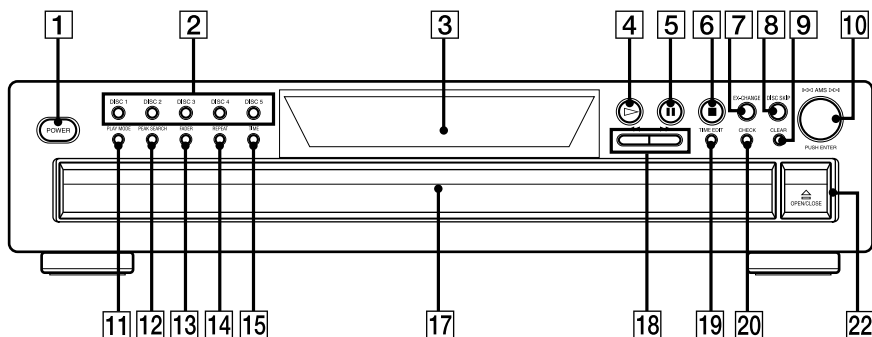

CHECK **20** (11, 12)
 CLEAR **9** (11, 12)
 DISC 1-5 **2** (8, 9, 11)
 Disc compartment **17** (7)
 DISC SKIP **8** (7, 10, 12)
 Display **3** (9)
 EX-CHANGE **7** (10, 13)
 FADER **13** (12)
 PEAK SEARCH **12** (13)

PHONES jack **21** (9)
 PLAY MODE **11** (8, 9, 11, 13)
 POWER **1** (7)
 Remote sensor **16** (6)
 REPEAT **14** (8)
 TIME **15** (9, 10)
 TIME EDIT **19** (12)

BUTTON DESCRIPTIONS

⏏ OPEN/CLOSE **22** (7, 9)
 ▷ **4** (8, 11, 13)
 ■ **5** (9, 13)
 ■ **6** (9, 13)
 ⏪⏩AMS⏪⏩ dial **10** (9, 11, 13)
 ◀▶▶▶ **18** (9, 12)

Rear Panel

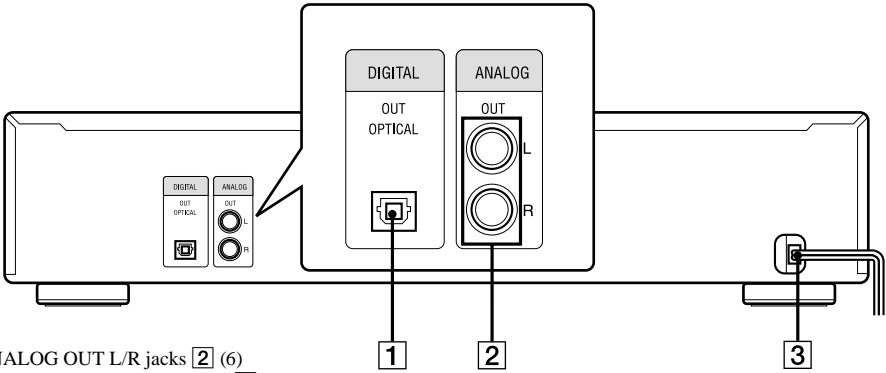

- ANALOG OUT L/R jacks **2** (6)
 DIGITAL OUT OPTICAL jack **1** (7)
 Mains lead **3** (6)

Remote Control (CDP-CE375 only)

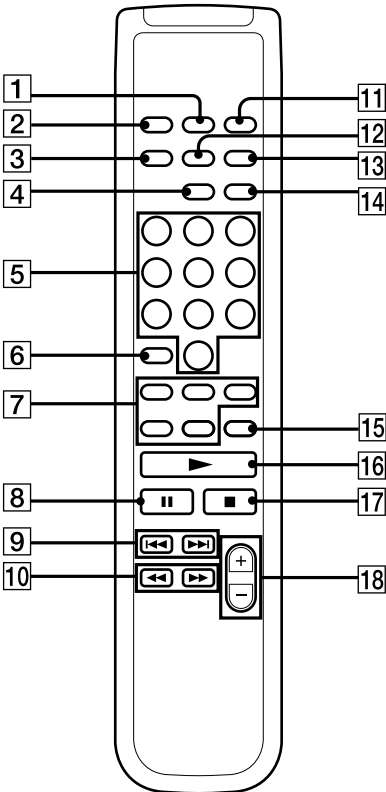

- ANALOG OUT LEVEL +/- **18**
 (6, 7)
 CHECK **12** (11, 12)
 CLEAR **13** (11, 12)
 CONTINUE **2** (8)
 DISC 1-5 **7** (8, 9, 11)
 DISC SKIP **15** (7, 10, 12)
 FADER **14** (12)
 Number buttons **5** (9, 11)
 PROGRAM **11** (8)
 REPEAT **3** (8)
 SHUFFLE **1** (8)
 TIME **4** (9, 10)

BUTTON DESCRIPTIONS

- >10 **6** (9)
 ► **16** (8, 11, 13)
 ■ **8** (9, 13)
 ■ **17** (9, 13)
 ◀◀ AMS ▶▶ **9** (9, 11, 13)
 ◀◀▶▶ **10** (9, 12)

Inserting Batteries Into the Remote Control (CDP-CE375 only)

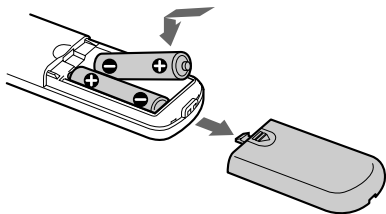

You can control the player using the supplied remote.

Insert two R6 (size AA) batteries by matching the + and – on the batteries to the diagram inside the battery compartment.

Insert the negative (–) end first, then push in and down until the positive (+) end clicks into position.

When using the remote, point it at the remote sensor  on the player.

Tip

When the remote no longer operates the system, replace both batteries with new ones.

Note

- Do not leave the remote near an extremely hot or humid place.
- Do not drop any foreign object into the remote casing, particularly when replacing the batteries.
- Do not expose the remote sensor to direct sunlight or lighting apparatuses. Doing so may cause a malfunction.
- If you don't use the remote for an extended period of time, remove the batteries to avoid possible damage from battery leakage and corrosion.

Hooking Up the System

Hookups

This section describes how to hook up the CD player to an amplifier. Be sure to turn off the power of each component before making the connections.

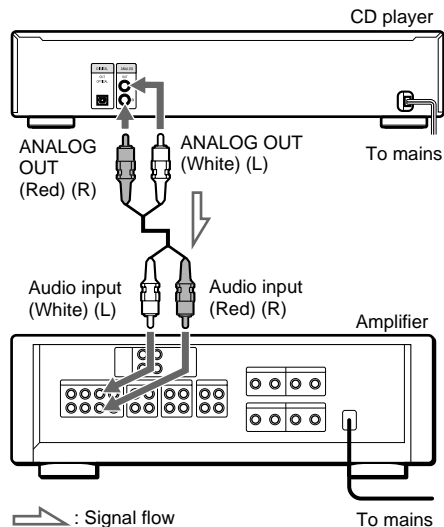

Tip (CDP-CE375 only)

You can adjust the analog output level to the amplifier using the remote comes with this player. Press ANALOG OUT LEVEL +/- on the remote. You can reduce the output level up to –20 dB. When you reduce the analog output level, “FADE” appears in the display. When you turn off the player, the analog output level automatically returns to the maximum level.

Making digital hookups

If you have a digital component such as a digital amplifier, D/A converter, DAT, or MD, connect the component via the DIGITAL OUT (OPTICAL) connector using the optical cable (not supplied). Take off the cap and plug in the optical cable.

Note that you cannot use the following functions when making this connection:

- Fading In or Out (see page 12)
- Adjusting the output level using the ANALOG OUT LEVEL +/- buttons on the remote

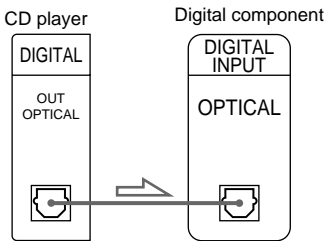
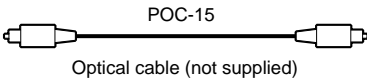

Note

When you connect via the DIGITAL OUT (OPTICAL) connector, noise may occur when you play CD software other than music, such as a CD-ROM.

Transporting the player

Before transporting the player, follow the procedure below to return the internal mechanisms back to their original position.

- 1 **Remove all the discs from the disc tray.**
- 2 **Press \triangle OPEN/CLOSE to close the disc tray.**
“no DISC” appears in the display.
- 3 **Wait for 10 seconds, then press POWER to turn off the player.**

Loading a CD

- 1 **Turn on the amplifier and select the CD player position so that you can listen to the sound from this player.**
- 2 **Press POWER to turn on the player.**
- 3 **Press \triangle OPEN/CLOSE.**
The disc compartment slides out.
- 4 **Place a disc on the disc tray with the label side up.**

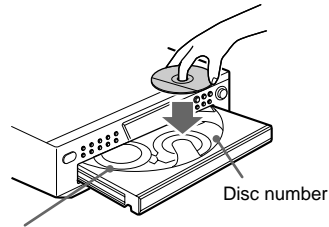

When you play a CD single, place it on the inner circle of the tray.

- 5 **To place other discs, press DISC SKIP and place the discs in the order you want to play.**
Each time you press the button, the disc tray turns and you can place the discs in the empty disc compartments. The player plays the disc in front of you first.
- 6 **Press \triangle OPEN/CLOSE to close the disc compartment.**

Playing the CD

—Normal Play/Shuffle Play/Repeat Play

This unit lets you play the CD in different play modes.

1 Press **PLAY MODE** repeatedly until the mode you want appears.

Select	To play
ALL DISCS (Continuous Play)	All discs in the player consecutively in the order of disc number.
1 DISC (Continuous Play)	Only the disc you've selected.
ALL DISCS SHUFFLE	All tracks on all discs in random order.
1 DISC SHUFFLE	All tracks on the specific disc in random order.
PROGRAM	The tracks on the CD in the order you want them to be played (see "Programming the CD tracks" on page 11).

2 Press **▷**.

Tips

- You can select the disc you want to start playing first by pressing one of the DISC 1 – 5 buttons.
- You can specify discs during ALL DISCS Shuffle Play mode, and the tracks on the specified discs are played in a random order.

Press DISC 1 – 5 to specify the discs after Step 1.

Semi-circles appear around the specified disc numbers in the display. To cancel the selected discs, press DISC 1 – 5 again. The semi-circles disappear. To return to ALL DISCS Shuffle Play, press **PLAY MODE** until "ALL DISCS SHUFFLE" appears in the display.

- You can select the playing mode by pressing **CONTINUE**, **SHUFFLE**, or **PROGRAM** on the remote (CDP-CE375 ONLY).

Repeat Play Operations

You can play the CD tracks repeatedly in any play modes.

To activate the Repeat Play function, press **REPEAT** until "REPEAT" appears in the display.

To	Press REPEAT
Repeat only one track	Until "REPEAT 1" appears while playing the track you want to repeat.
Cancel Repeat Play	Until "REPEAT" or "REPEAT 1" disappears.

When you are in the Repeat Play function, the player repeats the tracks as follows:

When the disc is played in	The player repeats
Continuous Play (ALL DISCS)	All the tracks on all discs
Continuous Play (1 DISC)	All the tracks on the current disc
Shuffle Play (ALL DISCS)	All the tracks on all discs in random order
Shuffle Play (1 DISC)	All the tracks on the current disc in random order
Program Play (page 11)	The same program

Other Operations

To	Do this
Stop playback	Press ■.
Pause	Press ■■. Press ■■ again or ▷ to resume play.
Select a track	During play or pause, turn ◀◀◀AMS▶▶▶ clockwise (to go forward) or counterclockwise (to go backward) (or press ▶▶▶ (to go forward) or ◀◀◀ (to go backward) on the remote (CDP-CE375 only)).
Select a track directly	Press the number button on the remote (CDP-CE375 only).*
Go to the next disc	Press DISC SKIP.
Select a disc directly	Press DISC 1 – 5.
Find a point in a track	Press and hold ▶▶▶ or ◀◀◀ during playback, and release at the desired point.
Play tracks in random order	Press PLAY MODE until “SHUFFLE” appears in the display.
Remove the CD	Press OPEN/CLOSE.
Adjust the volume	Press ANALOG OUT LEVEL +/- on the remote (CDP-CE375 only).

* When you directly locate a track numbered over 10, press >10 first, then the corresponding number buttons. To enter “0,” use button 10.

Example: To play track number 30
Press >10 first, then 3 and 10.

Tips

- You can adjust the analog output level with the ANALOG OUT LEVEL +/- on the remote (page 6) (CDP-CE375 only).
- You can adjust the headphones volume on the remote. To adjust the volume, connect the headphones to the PHONES jack and adjust the volume with the ANALOG OUT LEVEL +/- on the remote (CDP-CE375 only).
- If there is no CD in the player, “no dISC” appears in the display.

Notes

- If “⌂” appears in the display, the disc has reached the end while you were pressing ▶▶▶. Press ◀◀◀ or turn ◀◀◀AMS▶▶▶ counterclockwise to go back.
- If you press ANALOG OUT LEVEL +/- on the remote while recording, the recording level will change even when it is preset on the tape deck, etc (CDP-CE375 only).

Using the CD display

You can check information about the disc using the display.

In the stop mode

Press TIME.

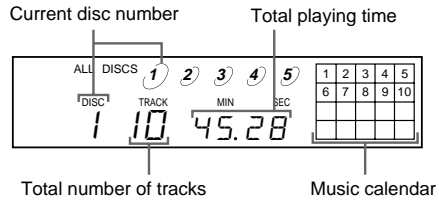

The display shows the current disc number, the total number of tracks, total playing time and music calendar.

The information also appears when you press OPEN/CLOSE to close the disc tray.

The tracks numbered over 20 cannot be displayed in the music calendar.

Notes on the disc number indications

- The red circle around a disc number indicates the disc is ready to be played.
- When all the tracks on a disc have been played, the semi-circle around the disc number disappears.
- When a disc compartment is recognized as empty, the semi-circled disc number disappears.

During normal playback

While playing a disc, the display shows the current disc number, track number, playing time of the track and the music calendar.

The track numbers in the music calendar disappear after they are played.

continued

Using the CD display (continued)

To check the remaining time

Press TIME during playback.

Each time you press this button while playing a disc, the display changes as shown in the chart below.

Playing time and number on the current track
→ Remaining time on the current track →
Remaining time on the disc

Notes

- When the disc has more than 24 tracks, “-- . --” appears instead of the remaining time.
- The remaining time on the disc appears only when the disc is played in Continuous Play.

Replacing Discs While Playing a Disc

You can open the disc tray while playing a disc so that you can check what discs are to be played next and replace discs without interrupting playback of the current disc.

1 Press EX-CHANGE.

The disc tray opens and two disc compartments appear. Even if the player is playing a disc, it doesn't stop playing.

2 Replace discs in the compartments with new ones.

The player plays the disc on the left side compartment after the current disc, and then the one on the right side compartment.

3 Press DISC SKIP.

The disc tray turns and other two disc compartments appear.

4 Replace discs in the compartments with new ones.

5 Press EX-CHANGE.

The disc tray closes.

While the disc tray is open by pressing the EX-CHANGE button

- If the playback of the current disc ends, the player stops playing. If the disc is played in 1 DISC Repeat Play mode (see page 8), the current disc starts playing again.
- In ALL DISCS Shuffle Play mode (see page 8), tracks are reshuffled on the current disc.
- In Program Play mode (see page 11), only the tracks on the current disc are played.
- **Do not push the disc tray to close it in Step 5, as you may damage the player.**

Programming the CD tracks

You can arrange the order of the tracks on the discs and create your own program. The program can contain up to 32 “steps” — one “step” may contain a track or a whole disc.

1 Press **PLAY MODE** repeatedly until “PROGRAM” appears in the display before you start playing.

If a program is already stored, the last step of the program appears in the display. When you want to erase the whole program, hold down **CLEAR** until “ALL CLR” appears in the display (see page 12).

2 Press **DISC 1 – 5** to select the disc.

“AL” in the display stands for “all” tracks. When you want to program the whole disc as one step, skip Step 3, and go to Step 4.

3 Turn **◀◀AMS▶▶** until the track you want appears and push **◀◀AMS▶▶** to select the track.

The track number that you programmed, the playing order, and the total playing time appear in the display.

If you’ve made a mistake
Press **CLEAR**, then repeat Step 2.

Tip

You can select the track using the number buttons on the remote. To select a track with a number over 10, use >10 (see page 9).

4 To program other discs or tracks, do the following:

To program	Repeat Step(s)
Other discs	2
Other tracks on the same disc	3
Other tracks on other discs	2 and 3

5 Press **▷** to start Program Play.

To cancel Program Play
Press **PLAY MODE**.

Tips

- You can create your program while checking the disc labels.
While the disc tray is open, follow Steps 1 to 4 with pressing the **DISC SKIP** button to check the disc labels. If you close the disc tray before Step 5, the total playing time appears in the display after a while.
Note that, if the programmed track number isn’t found on the disc, that step is automatically erased.
- The program remains even after the Program Play ends. When you press the **▷** button, you can play the same program again.
- The program remains until you erase it or turn off the player. If you replace discs, the programmed disc and track numbers remain. So, the player plays only the existing disc and track numbers. However, the disc and track numbers that aren’t found in the player or on the disc are deleted from the program, and the rest of the program is played in the programmed order.
- For the recording to the A side or B side of the cassette tape, you can pause Program Play.

Note

- The total playing time doesn’t appear when:
- You have programmed a track whose number exceeds 20.
 - The total playing time of the program exceeds 200 minutes.

Checking the track order

You can check your program before or after you start playing.

Press **CHECK**.

Each time you press this button, the display shows the track (the disc and track numbers) or the disc (the disc number and “AL” indication) of each step in the programmed order. After the last step in the program, the display shows “End” and returns to the original display. If you check the order after you start playing, the display shows only the remaining steps.

continued

Programming the CD tracks (continued)

Changing the track order

You can change your program before you start playing.

To	You need to
Erase a track	Press CHECK until the track you don't want appears in the display, then press CLEAR.
Erase the last track in the program	Press CLEAR. Each time you press the button, the last track will be cleared.
Add tracks to the end of the program	Follow Steps 2 through 4 of the programming procedure.
Change the whole program completely	Hold down CLEAR until "ALL CLr" appears in the display. Create a new program following the programming procedure.

Fading In or Out

You can manually fade in or out to prevent tracks from starting or ending abruptly.

Note that you cannot use this effect when you use the DIGITAL OUT (OPTICAL) connector.

To	Press FADER
Start play fading in	During pause. "FADE" flashes. The play fades in.
End play fading out	When you want to start fading out. "FADE" flashes. Then play fades out and the player pauses.

Fading time lasts for 5 seconds.

Recording a CD by Specifying Tape Length (Time Edit)

You can have the player create a program that will fit the length of the tape.

The player automatically creates a program, keeping the original order of the disc.

The program can contain up to 32 steps (a pause inserted between steps is counted as one step).

Note that tracks numbered over 20 cannot be programmed automatically.

- 1 Press **DISC SKIP** to select the disc.
- 2 Press **TIME EDIT** repeatedly before you start playing until "EDIT" appears and "A" in the **(A)** indication flashes in the display.

- 3 Press **◀** or **▶** to specify the tape length.

Each time you press these buttons, the display changes as shown below, with the tape length of one side following each indication.

```

C-46 23.00 ↔ C-54 27.00 ↔ C-60 30.00
  ↓                               ↓
  - - - ↔ C-90 45.00 ↔ C-74 37.00
  
```

- 4 Press **TIME EDIT** to have the player create the program.

The display shows the tracks to be recorded. "B" in the **(A)** indication flashes in the display.

- 5 When you record on both sides of the tape, press **TIME EDIT** again.

The player inserts a pause, then creates the program for side B. The display shows the programmed tracks.

When you record on one side of the tape, skip this step.

- 6 Start recording on the deck and then press \triangleright on the player.
- 7 Reverse the tape to side B and press \triangleleft or **II** on the player to resume playing the remaining tracks.

To cancel Time Edit

Press PLAY MODE.

Tips

- You can program the tracks you want in advance. Create a program selecting the desired tracks, then follow Steps 2 to 7. Be careful that the total playing time of the program does not exceed the tape length of one side.
- You can set the tape length freely using \lll AMS \ggg .
 - Example: When the tape length of one side is 30 minutes and 15 seconds
 - 1 To set the minutes, turn \lll AMS \ggg until “30” appears in the display, then push \lll AMS \ggg .
 - 2 To set the seconds, turn \lll AMS \ggg until “15” appears in the display, then push \lll AMS \ggg .
- To check and change your program, see pages 11 and 12.

Adjusting the Recording Level (Peak Search)

The player locates the highest level among the tracks to be recorded to let you adjust the recording level before you start recording.

1 Before you start playing, press PEAK SEARCH.

“PEAK” flashes in the display and the player starts scanning the disc searching for the highest peak level.

After scanning all the tracks, the player repeats the portion with the highest peak level.

2 Adjust the recording level on the deck.

3 Press \blacksquare on the player to stop Peak Search.

“PEAK” disappears from the display.

Notes

- The portion with the highest level may differ every time you try the adjustment on the same disc. The difference is, however, so slight that you won’t find any problem in adjusting the recording level precisely.
- Peak Search does not operate while you open the disc tray by pressing the EX-CHANGE button.

Precautions

On safety

- Caution — The use of optical instruments with this product will increase eye hazard.
- Should any solid object or liquid fall into the cabinet, unplug the player and have it checked by qualified personnel before operating it any further.
- Discs with non-standard shapes (e.g., heart, square, star) cannot be played on this unit. Attempting to do so may damage the unit. Do not use such discs.

On power sources

- Before operating the player, check that the operating voltage of the player is identical with your local power supply. The operating voltage is indicated on the nameplate at the rear of the player.
- The player is not disconnected from the AC power source (mains) as long as it is connected to the wall outlet, even if the player itself has been turned off.
- If you are not going to use the player for a long time, be sure to disconnect the player from the wall outlet. To disconnect the AC power cord (mains lead), grasp the plug itself; never pull the cord.
- AC power cord must be changed only at the qualified service shop.

On placement

- Place the player in a location with adequate ventilation to prevent heat build-up in the player.
- Do not place the player on a soft surface such as a rug that might block the ventilation holes on the bottom.
- Do not place the player in a location near heat sources, or in a place subject to direct sunlight, excessive dust or mechanical shock.

On operation

- If the player is brought directly from a cold to a warm location, or is placed in a very damp room, moisture may condense on the lenses inside the player. Should this occur, the player may not operate properly. In this case, remove the disc and leave the player turned on for about an hour until the moisture evaporates.

On adjusting volume

- Do not turn up the volume while listening to a portion with very low level inputs or no audio signals. If you do, the speakers may be damaged when a peak level portion is played.

On cleaning

- Clean the cabinet, panel and controls with a soft cloth slightly moistened with a mild detergent solution. Do not use any type of abrasive pad, scouring powder, or solvent such as alcohol or benzene.

If you have any questions or problems concerning your player, please consult your nearest Sony dealer.

Notes on CDs

On handling CDs

- To keep the disc clean, handle the disc by its edge. Do not touch the surface.
- Do not stick paper or tape on the disc.

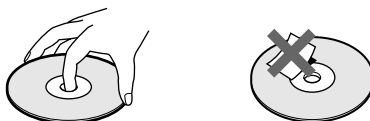

- Do not expose the disc to direct sunlight or heat sources such as hot air ducts, nor leave it in a car parked in direct sunlight as there can be considerable rise in temperature inside the car.
- Do not use any commercially available stabilizer. If you do, the disc and the player may be damaged.
- After playing, store the disc in its case.

On cleaning

- Before playing, clean the disc with a cleaning cloth. Wipe the disc from the centre out.

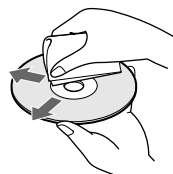

- Do not use solvents such as benzene, thinner, commercially available cleaners or anti-static spray intended for vinyl LPs.

Notes on CD-R/CD-RW playback

- Discs recorded on CD-R/CD-RW drives may not be played back because of scratches, dirt, recording condition, or the drive's characteristics. Besides, the discs, which are not yet finalized at the end of recording, cannot be played back.

Troubleshooting

If you experience any of the following difficulties while using the player, use this troubleshooting guide to help you remedy the problem. Should any problem persist, consult your nearest Sony dealer.

There's no sound.

- Check that the player is connected securely.
- Make sure you operate the amplifier correctly.
- Adjust the analog output level with ANALOG OUT LEVEL +/- on the remote (CDP-CE375 only).

The CD does not play.

- There's no CD inside the player. "no DISC" appears. Insert a CD.
- Place the CD with the label side up on the disc tray correctly.
- Clean the CD (see page 14).
- Moisture has condensed inside the player. Remove the disc and leave the player turned on for about an hour.
- Place the CD in the correct position on the disc tray.

The recording level has changed.

- The recording level changes if you adjust the analog output level with ANALOG OUT LEVEL +/- on the remote during recording (CDP-CE375 only).

The remote does not function (CDP-CE375 only).

- Remove the obstacles in the path of the remote and the player.
- Point the remote at the remote sensor  on the player.
- Replace all the batteries in the remote with new ones if they are weak.

The player functions incorrectly.

- The microcomputer chips may be operating incorrectly. Turn the power off, then turn it back on to reset the player.

Specifications

Compact disc player

Laser	Semiconductor laser ($\lambda = 780 \text{ nm}$) Emission duration: continuous
Frequency response	2 Hz to 20 kHz $\pm 0.5 \text{ dB}$
Dynamic range	More than 93 dB
Harmonic distortion	Less than 0.0045%

Outputs

	Jack type	Maximum output level	Load impedance
ANALOG OUT	Phono jacks	2 V (at 50 kilohms)	Over 10 kilohms
DIGITAL OUT (OPTICAL)	Optical output connector	-18 dBm	Wave length: 660 nm
PHONES (CDP-CE375 only)	Stereo phone jack	10 mW	32 ohms

General

Power requirements	120 V AC, 60 Hz
Power consumption	11 W
Dimensions (approx.) (w/h/d)	430 x 110 x 400 mm (17 x 4 3/8 x 15 3/4 in.) incl. projecting parts
Mass (approx.)	5 kg (11 lbs 1 oz)

Supplied accessories

Audio cord (2 phono plugs – 2 phono plugs) (1)
Remote commander (remote) (1) (CDP-CE375 only)
R6 (size AA) batteries (2) (CDP-CE375 only)

Design and specifications are subject to change without notice.

