

Masterbuilt Manufacturing, Inc
 450 Brown Avenue
 Columbus, Georgia 31906
 Customer Service 1-800-489-1581



**ASSEMBLY, CARE & USE MANUAL
 WARNING & SAFETY INFORMATION**

MODELS 20070106, 20070206
 DIGITAL SMOKEHOUSE

THIS PRODUCT IS FOR OUTDOOR USE ONLY ~ HOUSEHOLD TYPE

Manual Code: 988050015 rev 060824



Tools required for assembly: Phillips Head Screwdriver.

⚠ CARBON MONOXIDE HAZARD ⚠	⚠ WARNING ⚠
<p>Burning wood gives off carbon monoxide which can cause death.</p> <p>DO NOT burn wood chips inside homes, vehicles, tents, garages or any enclosed areas.</p> <p>Use only outdoors where it is well ventilated.</p>	<p>This manual contains important information necessary for the proper and safe use of this unit.</p> <p>Read and follow all warnings and instructions before using smoker and during use.</p> <p>Keep this manual for future reference.</p>
<p>Failure to follow these warnings and instructions properly could result in personal injury or death.</p>	



WARNINGS & IMPORTANT SAFEGUARDS



READ ALL INSTRUCTIONS.

- For outdoor use only. Do not operate in an enclosed area.
- Unit **MUST** be on the ground. Do not place unit on tables or counters.
- Do not plug in electric smoker until fully assembled and ready for use.
- Use only approved grounded electrical outlet.
- Do not use during an electrical storm.
- Do not expose electric smoker to rain or water at anytime.
- To protect against electrical shock do not immerse cord, plug or control panel in water or other liquid.
- Do not operate any appliance with a damaged cord or plug, or after appliance malfunctions or has been damaged in any manner. Contact Masterbuilt Customer Service for assistance at 1-800-489-1581.
- Keep a fire extinguisher accessible at all times while operating electric smoker.
- Do not let cord hang touch hot surfaces.
- Do not place on or near a hot gas or electric burner, or in a heated oven.
- Keep children and pets away from electric smoker at all times. Do not allow children to use electric smoker. Close supervision is necessary should children or pets be in area where electric smoker is being used.
- Fuel, such as charcoal briquettes or heat pellets, are not to be used in electric smoker.
- Never use electric smoker as a heater (READ CARBON MONOXIDE HAZARD).
- Use electric smoker only on a level, stable surface to prevent tipping.
- Electric smoker is HOT while in use and will remain HOT for a period of time afterwards. Use caution.
- Do not touch HOT surfaces.
- Do not allow anyone to conduct activities around electric smoker during or following its use until the unit has cooled. Electric smoker is HOT during operation and remains HOT for a period of time following use.
- The use of alcohol, prescription or non-prescription drugs may impair the user's ability to properly assemble or safely operate electric smoker.

WARNINGS & IMPORTANT SAFEGUARDS CONTINUED ON PAGE 2

WARRANTY INFORMATION

Masterbuilt warrants its products to be free from defects in material and workmanship under proper assembly, normal use and recommended care for 90 days from the date of original retail purchase.

Masterbuilt warranty does not cover paint finish as it may burn off during normal use.

Masterbuilt warranty does not cover rust of the unit.

Masterbuilt requires reasonable proof of purchase for warranty claims and suggests that you keep your receipt. Upon the expiration of such warranty, all such liability shall terminate.

Within the stated warranty period, Masterbuilt, at its discretion, shall repair or replace defective components free of charge with owner being responsible for shipping. Should Masterbuilt require return of component(s) in question for inspection Masterbuilt will be responsible for shipping charges to return requested item.

This warranty excludes property damage sustained due to misuse, abuse, accident, damage arising out of transportation, or damage incurred by commercial use of this product.

This expressed warranty is the sole warranty given by Masterbuilt and is in lieu of all other warranties, expressed or implied including implied warranty, merchantability, or fitness for a particular purpose.

Neither Masterbuilt nor the retail establishment selling this product, has authority to make any warranties or to promise remedies in addition to or inconsistent with those stated above.

Masterbuilt's maximum liability, in any event, shall not exceed the purchase price of the product paid by the original consumer/ purchaser. Some states do not allow the exclusion or limitation of incidental or consequential damages. In such a case, the above limitations or exclusions may not be applicable.

California residents only: Notwithstanding this limitation of warranty, the following specific restrictions apply; if service, repair, or replacement of the product is not commercially practical, the retailer selling the product or Masterbuilt will refund the purchase price paid for the product, less the amount directly attributable to use by the original buyer prior to the discovery of the nonconformity. Owner may take the product to the retail establishment selling this product in order to obtain performance under warranty.

This expressed warranty gives you specific legal rights, and you may also have other rights which vary from state to state.

COMPLETE & RETURN TO

ATTN: WARRANTY REGISTRATION

Masterbuilt Manufacturing, Inc.

450 Brown Avenue, Columbus, GA 31906

Name: _____

Address: _____

City, State/Province, Postal Code: _____

Phone Number: _____ E-Mail Address: _____

Model Number: _____ Serial Number: _____

Purchase Date: _____ Place of Purchase: _____

MASTERBUILT SMOKIN' RECIPES continued

SMOKED HAMBURGER JERKY

INGREDIENTS:	
Ground beef (lean)	2 lbs (0.91 kg)
Ginger (grated)	2 tsp
Allspice	1 tbs
Sugar	4 tbs
Garlic (minced)	1 clove
Soy sauce	½ cup

SUGGESTED WOOD FOR SMOKING:
Hickory or Mesquite chips

INSTRUCTIONS:
Press hamburger meat into flat strips 5" (13cm) long by 1 ½" (4cm) wide and ¼" (6mm) thick. Place one layer of hamburger strips in dish for marinating. Combine all marinade ingredients in a small bowl until blended well. Sprinkle marinade over meat, soaking well. Turn meat over and again sprinkle with marinade. Add layers of hamburger strips to marinating dish and repeat sprinkling process until both are used. Cover tightly and let marinate in refrigerator for 6 to 10 hours. Rotate meat layers occasionally during this time. Place in smoker at 140°F (60°C). Cook for 4 hours.

VENISON JERKY

INGREDIENTS:	
Venison	2 lbs (0.91kg)
Brown sugar	½ cup
Worcestershire	½ cup
Garlic salt	½ tsp
Soy sauce	½ cup
Dry mustard	½ tsp
Salt	¼ cup
Pepper	dash
Water	3 cups

SUGGESTED WOOD FOR SMOKING:
Hickory or Mesquite chips

INSTRUCTIONS:
Cut meat into ¼" to ½" (6-13mm) thick strips about 5" (13cm) long and 1 ½" wide (4cm). Combine all marinade ingredients in a small bowl until blended well. Marinate meat for 6 to 8 hours. Dry and place in smoker at 140°F (60°C). Smoke for 12 to 16 hours.

SMOKE SAUSAGE

INGREDIENTS:
Fresh Pork or Beef sausage
Seasonings to taste

SUGGESTED WOOD FOR SMOKING:
Hickory or Mesquite chips

INSTRUCTIONS:
Place sausage in smoker at 150°F (65.5°C). Smoke for 5 to 6 hours or until outside casings begin to dry and change to a red color.

WOOD SMOKING GUIDE FOR MEATS

WOOD FLAVOR	POULTRY	FISH	HAM	BEEF	PORK	LAMB
Hickory Pungent, smoky, bacon-like flavor	✓	✓	✓	✓	✓	
Mesquite Sweet and delicate flavor	✓			✓		✓
Alder Delicate, wood smoke flavor	✓	✓			✓	
Pecan Bold and hearty flavor	✓	✓			✓	
Maple Sweet, subtle flavor	✓				✓	
Apple Sweet, delicate flavor	✓	✓			✓	
Cherry Sweet, delicate flavor	✓				✓	



WARNINGS & IMPORTANT SAFEGUARDS continued



- Avoid bumping or impacting electric smoker.
- Never move electric smoker when in use. Allow electric smoker to cool completely before moving or storing.
- Be careful when removing food from electric smoker. All surfaces are HOT and may cause burns. Use protective gloves or long, sturdy cooking tools.
- Do not cover cooking racks with metal foil. This will trap heat and cause severe damage to electric smoker.
- Drip tray is only for the bottom of electric smoker. Do not put drip tray on cooking racks this may damage electric smoker.
- Wood tray is HOT when electric smoker is in use. Use caution when adding wood.
- To disconnect, turn control panel "OFF" then remove plug from outlet.
- Unplug from outlet when not in use and before cleaning. Allow unit to cool completely before adding/removing grates, tray or water bowl.
- Dispose of cold ashes by placing them in aluminum foil, soaking with water and discarding in a non-combustible container.
- Do not store electric smoker with HOT ashes inside unit. Store only when all surfaces are cold.
- Accessory attachments not supplied by Masterbuilt Manufacturing, Inc. are not recommended and may cause injury.
- Never use electric smoker for anything other than its intended purpose. This unit is not for commercial use.
- Always use electric smoker in accordance with all applicable local, state and federal fire codes.

SAVE THESE INSTRUCTIONS.



IMPORTANT INFORMATION



DO NOT USE AN EXTENSION CORD WITH THIS PRODUCT

- Use of an extension cord causes loss of energy and unit may not heat properly.
- Use of an extension cord increases risk of entanglement or tripping.



WARNING



Combustion by-product produced when using this product contains chemicals known to the State of California to cause birth defects, other reproductive harm, or cancer.

PARTS LIST

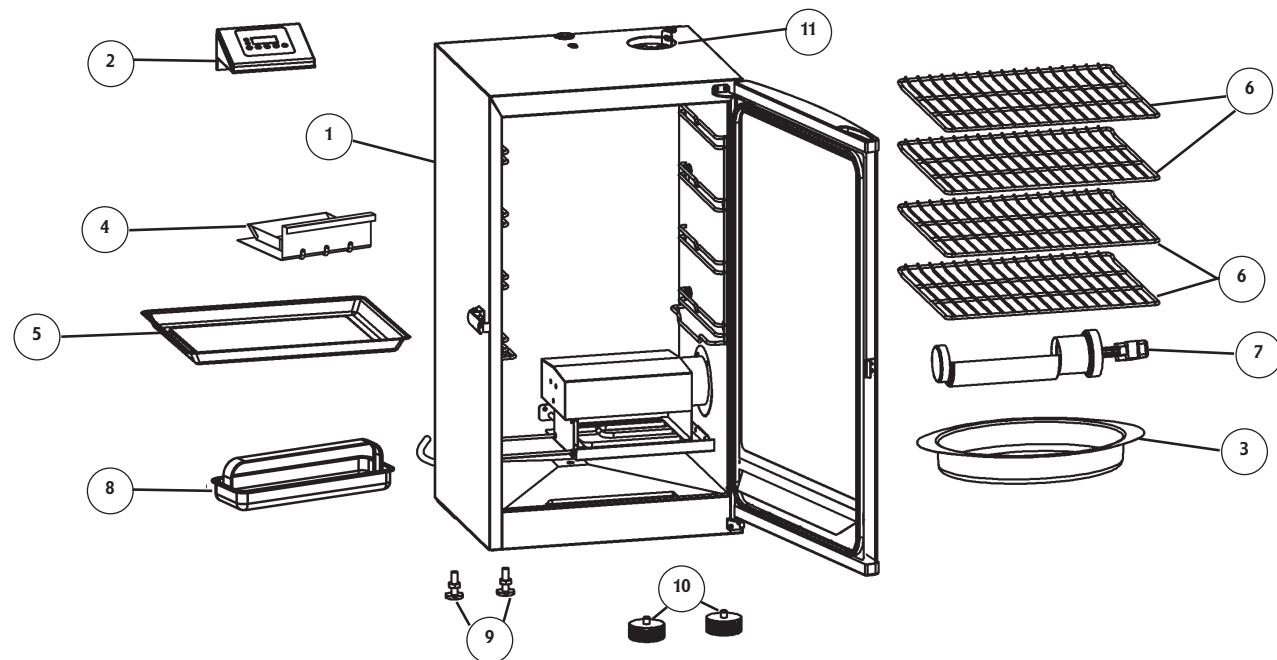

ITEM NO.	QUANTITY	DESCRIPTION	ITEM NO.	QUANTITY	DESCRIPTION
1	1	Smoker Body	7	1	Wood Chip Loader
2	1	Digital Control Panel	8	1	Grease Tray
3	1	Water Bowl	9	2	Adjustable Screw Leg (premounted)
4	1	Wood Chip Holder	10	2	Leg Boot (premounted)
5	1	Drip Pan	11	1	Air Damper (premounted)
6	4	Cooking Grates	12	1	Heating Element (premounted, not shown)

REPLACEMENT PARTS LIST

ITEM NO.	DESCRIPTION	ITEM NO.	DESCRIPTION
990050047	Door Kit-20070106 (Black)	990050053	Element Support Rack Kit
990060079	Door Kit-20070206 (Stainless Steel)	910050029	Cooking Grate
990050048	Digital Control Panel Kit	910050030	Water Bowl
990050049	Cooking Grate Support Rack Kit	910050023	Wood Chip Loader
990050050	Wood Chip Holder Kit	910050031	Drip Pan
990050051	Element Kit	910060047	Grease Tray
990050052	Body Kit -20070106 (Black)	910050006	Adjustable Screw Leg
990060080	Body Kit-20070206 (Stainless Steel)	910050009	Leg Boot
990060221	Air Damper Kit	988050015	Instruction Manual
990050222	Door Latch Kit	998050010	Hardware Kit
910060061	Door Seal		

STOP!

DO NOT RETURN TO RETAILER
For Assembly Assistance, Missing or Damaged Parts
Call: MASTERBUILT Customer Service at 1-800-489-1581

MASTERBUILT SMOKIN' RECIPES continued

SMOKED STUFFED SALMON

Servings for 4

INGREDIENTS:

Salmon (drawn)	4 - 5 lbs (1.8-2.2 kgs)
Oil	3 tbs
Green onion (chopped)	¼ cup
Tomato (peeled and chopped)	1 cup
Dill (fresh and chopped)	¼ cup
Bread cubes (dry)	¼ cup
Celery (chopped)	¼ cup
Salt	¼ tsp
Lemon pepper	½ tsp
Garlic (minced)	1 clove

SUGGESTED WOOD FOR SMOKING:
Hickory chips

INSTRUCTIONS:
Prepare salmon and brush with oil. Combine remaining ingredients in a small bowl. Stuff salmon with mixture. Place salmon on a sheet of heavy aluminum foil that has been doubled and greased. Place in smoker at 225°F (107°C) and cook for 3 to 4 hours. Make sure there is room on either side of foil to allow airflow inside smoker.

SMOKED TROUT

Servings for 6

INGREDIENTS:

Trout fillets	4 - 6
Water	2 cups
Soy sauce	¼ cup
Teriyaki sauce	¼ cup
Salt	¼ cup
Lemon pepper	1 tsp
Garlic salt	
Dill seed	

SUGGESTED WOOD FOR SMOKING:
Hickory, alder or apple chips

INSTRUCTIONS:
Mix recommended amounts of water, soy sauce, teriyaki sauce and salt with other ingredients to your liking in a small container. Place fillets into marinade, cover and let soak in refrigerator overnight. Smoke for 3 to 4 hours or until meat is flaky and dry in smoker at 225°F (107°C).



SMOKED TUNA

Servings for 4

INGREDIENTS:

Tuna steaks-1" thick (2.5cm)	4
Sugar	1 ½ cups
Salt	¾ cup
Pepper	1 tsp
Garlic (granulated)	¼ tsp
Prague powder #1	¼ tsp
Honey	1 cup
Water	1 gal (3.8L)

SUGGESTED WOOD FOR SMOKING:
Hickory or apple chips

INSTRUCTIONS:
Mix above ingredients until dissolved in water. Place in smoker at 140°F (60°C) and cook for about 7 hours using water mixture in water bowl.

SMOKED FISH

Servings for 4

INGREDIENTS:

Fish fillets or whole fish	4
White wine (dry)	1 cup
Parsley (dried)	1 tbs
Lemon (cut up)	1 small
Cayenne pepper	

SUGGESTED WOOD FOR SMOKING:
Hickory or pecan chips

INSTRUCTIONS:
Salt and pepper fish to taste. Mix above ingredients with water for use in water bowl. Layer fish on greased cooking rack and place in smoker at 140°F (60°C). Cook for about 2 hours.



SMOKED SUMMER VEGETABLES

Servings for 4-6

INGREDIENTS:

Summer Squash
Zucchini
Onion
Mushrooms
French Cut Green Beans

SUGGESTED WOOD FOR SMOKING:
Hickory or apple wood chips

INSTRUCTIONS:
Rinse and thinly slice summer squash, zucchini and onion. Mix all vegetables together. Form cup shaped containers using heavy duty aluminum foil. Place about 1 cup of vegetable mix in each foil cup. Season to taste with your favorite herbs and spices. Pinch top of foil cups together. To allow smoke penetration put a couple of small holes around top of each vegetable cup. Place foil cups in smoker at 220°F (104°C) for 1 hour. Serve.

MASTERBUILT SMOKIN' RECIPES

PORK OR BABY BACK RIBS

Servings for 4-6

INGREDIENTS:

Ribs	2-4 lbs (0.91-1.8 kgs)
Sugar	½ cup
Salt	½ cup
Brown sugar	¼ cup
Chili Powder	2 ½ tbs
Ground Cumin	1 ½ tbs
Cayenne Pepper	2 tsp
Black Pepper (freshly ground)	2 tsp
Garlic Powder	2 tsp
Onion Powder	2 tsp

SUGGESTED WOOD FOR SMOKING:

Hickory chips

INSTRUCTIONS:

Mix ingredients and rub mixture on meat 2 hours before cooking. Allow meat to reach room temperature. Cook ribs for 3 hours at 225°F (107°C) in smoker using hickory chips during first 2 hours. After 3 hours remove ribs and wrap in heavy foil. Cook for an additional 1 to 1 ½ hours. Serve.

SMOKED CORNISH HENS

w/ Wild Rice

Servings for 2

INGREDIENTS:

Cornish Game Hens	2 hens
Green onion (chopped)	¼ cup
Butter	3 tbs
Wild rice (cooked)	1 cup
Pecans or Walnuts (chopped)	¼ cup
Lime Marmalade	½ cup
Orange juice	¼ cup
Salt	

SUGGESTED WOOD FOR SMOKING:

Hickory chips

INSTRUCTIONS:

Rinse and pat dry each hen. Season cavities with salt. Sauté onions in 1 tbs butter. Stir in rice and chopped nuts. Stuff hens with rice mixture. Close with skewers or kitchen string. Melt remaining 2 tbs of butter in small saucepan. Add marmalade and orange juice blending until smooth. Brush hens with marmalade mixture. Place hens on cooking rack in 225°F (107°C) smoker and cook for 2 to 2 ½ hours. Brush with remaining glaze before serving.

SMOKED FILET MIGNON

Servings for 20

INGREDIENTS:

Beef Filets	4 lbs (1.8 kgs)
Olive oil	2 tbs
Garlic cloves (crushed)	4 cloves
Salt	
Ground Pepper	

SUGGESTED WOOD FOR SMOKING:

Mesquite or cherry wood chips

INSTRUCTIONS:

Season meat with garlic cloves, salt and pepper. Heat olive oil in large frying pan. Sear/brown meat on all sides. This will seal in juices before smoking. Wrap each filet in heavy aluminum foil leaving the tops of each uncovered. Sprinkle a little olive oil on top of each filet. Place foil wrapped filets in 225°F (107°C) smoker and cook 20 to 30 minutes. Medium rare filet will have an internal temperature of 140°F (60°C) when checked with thermometer. Allow meat to cool slightly then carve into ½" slices. Serve at room temperature.

SMOKED PORK BUTT

Servings for 6

INGREDIENTS:

Fresh Pork Butt	7 lbs (3.1kgs)
Salt	½ tsp
Brown sugar	¼ cup
Chili Powder	2 tbs

SUGGESTED WOOD FOR SMOKING:

Apple chips

INSTRUCTIONS:

Mix ingredients and rub onto pork butt. Cook pork butt for 5 hours in 225°F (107°C) smoker using apple wood chips during first 3 hours. After 5 hours remove butt and wrap in heavy foil. Cook for an additional 1 to 1 ½ hours. Internal temperature should be 160°F (71°C). Serve.

MAPLE GLAZED HAM

Servings for 6-8

INGREDIENTS:

Ham shank or butt (fully cooked, bone-in)	5 - 7 lbs (2.2-3.1 kgs)
Maple syrup	1 ½ cup
Ginger	1 tsp
Nutmeg	¼ tsp
Allspice	½ tsp
Cloves	16 whole
Pineapple slices (canned)	1 can
Maraschino Cherries	1 jar

SUGGESTED WOOD FOR SMOKING:

Hickory or Mesquite chips

INSTRUCTIONS:

Remove thick skin and trim fat leaving no more than 1/2" (13mm) thick covering on ham. Score ham. Combine syrup, ginger, nutmeg, and allspice in a small bowl. Place ham in a large dish and baste with syrup mixture. Let ham stand in syrup mixture for 1 to 2 hours basting frequently until ham at room temperature. When ready to smoke remove ham from dish and stud with cloves. Place ham in 225°F (107°C) smoker. Cook for 2 to 3 hours. Baste with syrup mixture at least two times during cooking time. Before last hour of smoking, decorate ham with canned pineapple and cherries and baste. Internal temperature of ham should be at 130°F to 140°F (54-60°C) when heated thru.



SMOKED TURKEY

Servings for 6-8

INGREDIENTS:

Turkey	10 - 14 lbs (4.5-6.3 kgs)
Salt	1 tbs
Sugar	2 tbs
Cinnamon	1-2 tsps
Apple (cored, peeled, and quartered)	1 average
Onion (quartered)	2 medium
Celery stalks with leaves	4 stalks

SUGGESTED WOOD FOR SMOKING:

Hickory or Apple chips

INSTRUCTIONS:

Thaw turkey according to package directions if necessary. Remove giblets and neck. Rinse and pat dry. Sprinkle turkey cavity with salt. Combine sugar and cinnamon in small bowl. Dredge apple in mixture. Stuff apple, onion and celery into cavity. Close with skewers. Tie ends of legs to tail with kitchen string. Lift wing tips up and over the back to tuck under. Set smoker to 225°F (107°C). Place turkey on cooking rack and cook for 8 to 12 hours or until inner thigh temperature reaches 180°F (82°C). Cover turkey and chill or let stand 20 minutes before carving. Serve.

ASSEMBLY INSTRUCTIONS

Tools required for assembly: Phillips Head Screwdriver.

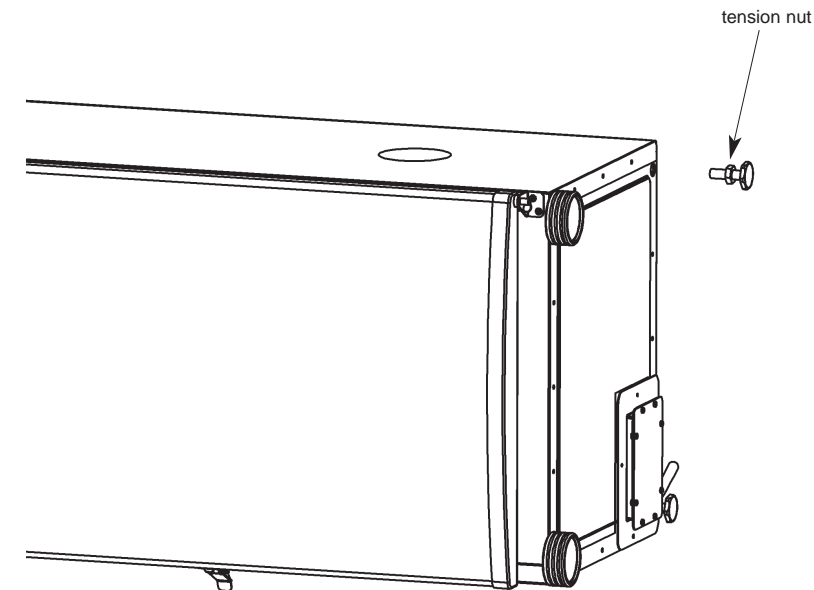

Step 1

Adjust feet by turning clockwise/counter-clockwise so that smoker is level when unit is upright. Once level, secure back leg positions with attached tension nuts.

Step 2

Position control panel to top of smoker.

Align slot on wire connector from control panel with tab on wire connector on smoker as shown and connect together.

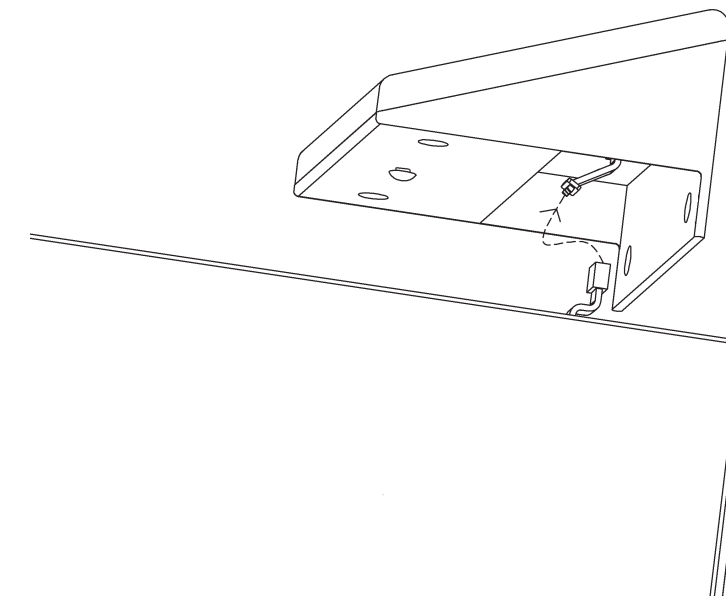

ASSEMBLY INSTRUCTIONS Continued

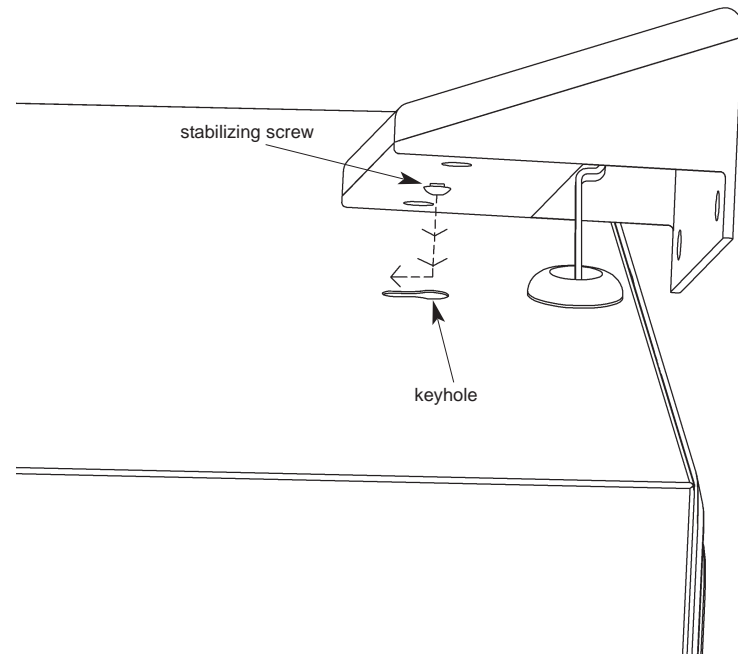

Step 3

Mount control panel by inserting stabilizing screw head into keyhole as shown.

Note: Stabilizing screw may need slight adjustment for snug fit.

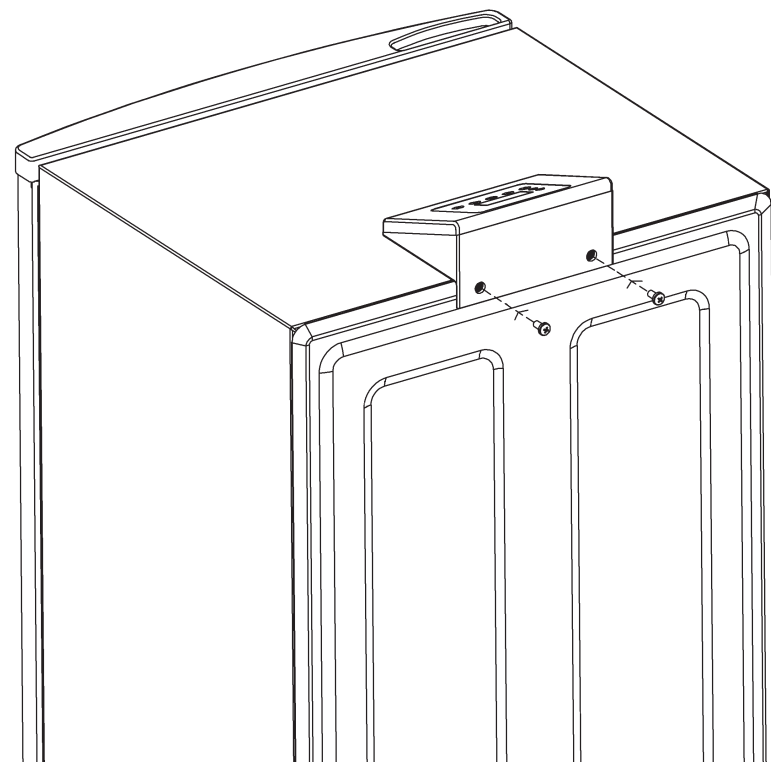

Step 4

Secure control panel to smoker with (2) m5X.08x10 panhead screws provided.

Note: Do not over tighten.

IMPORTANT FACTS ABOUT USING SMOKER

- Maximum temperature setting is 275°F (135°C).
- Wood chip loader and wood chip holder **MUST** be in place when using smoker. This minimizes the chance of wood flare ups.
- Wood chips must be used in order to produce smoke and create the smoke flavor. See "Wood Smoking Guide for Meats" section in this manual.
- This is a smoker. There will be a lot of smoke produced when using wood chips. Smoke will escape through seams and turn the inside of smoker black. This is normal.
- Check grease tray often during cooking. Empty grease tray when full. Grease tray may need to be emptied periodically during cooking.
- Do not open smoker door unless necessary. Opening smoker door causes heat to escape and may cause wood to flare up. Closing the door will re-stabilize the temperature and stop flare up.
- Do not leave old wood ashes in the wood tray. Once ashes are cold empty tray. Tray should be cleaned out prior to and after each use to prevent ash buildup.

HOW TO CLEAN SMOKER

For cooking racks, water bowl and drip tray use a mild dish detergent. Rinse and dry thoroughly.

For wood chip holder and wood chip loader, clean frequently to remove ash build up, residue and dust.

For the interior and exterior of smoker simply wipe down with a damp cloth. Do not use a cleaning agent. Make sure to dry thoroughly.

Door seal and inside seam that seal attaches to **MUST** be cleaned after each use to keep seal in proper working condition.

ALWAYS MAKE SURE UNIT IS UNPLUGGED AND COOL TO THE TOUCH BEFORE CLEANING AND STORING.

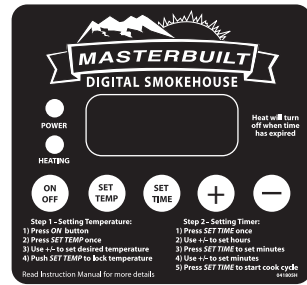

CONTROL PANEL OPERATING INSTRUCTIONS

It is not necessary to pre-heat this unit.

Note: Direct sunlight may interfere with reading LED display, block light if needed.

To set temperature:

- Press ON button.
- Press SET TEMP button once-LED display will blink.
- Use +/- to set temperature.
- Press SET TEMP button again to lock in temperature.

Note: Heating will not begin until timer is set.

To set timer:

- Press SET TIME button once-LED display for hours will blink.
- Use +/- to set hours.
- Press SET TIME button again to lock in hours. The minutes LED will start blinking.
- Use +/- to set minutes.
- Press SET TIME to lock in minutes and start cook cycle.

Heat will turn off when time has expired.

To RESET control panel:

If control panel shows an error message, turn electric smoker off, unplug unit from outlet, wait ten seconds, plug unit back into outlet, then turn electric smoker on. This will reset control panel.

ASSEMBLY INSTRUCTIONS Continued

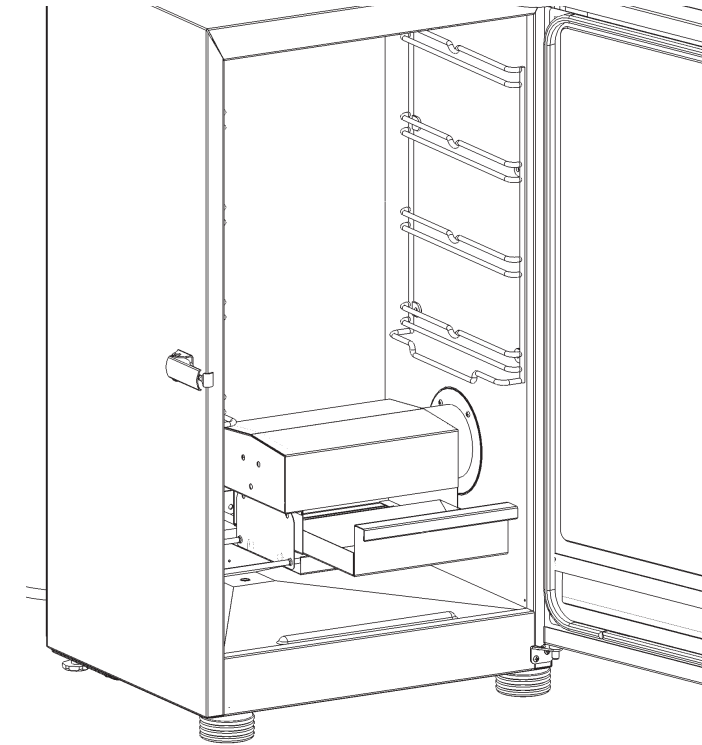

Step 5

Place wood chip holder in smoker as shown.

Note: Wood chip holder and wood chip loader **MUST** be in place when using smoker. This minimizes the chance of wood flare ups.

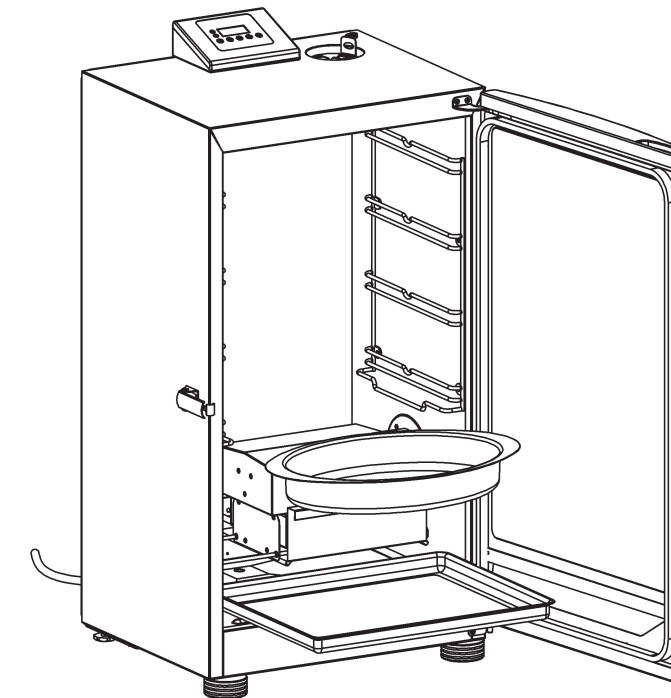

Step 6

Place water bowl onto lower bracket inside smoker.

Place drip tray inside smoker below heating element as shown.

Note: Water bowl must always be in place during smoking process, even if there is no water or other liquid in bowl. Bowl will prevent food from dripping onto wood chips.

ASSEMBLY INSTRUCTIONS Continued

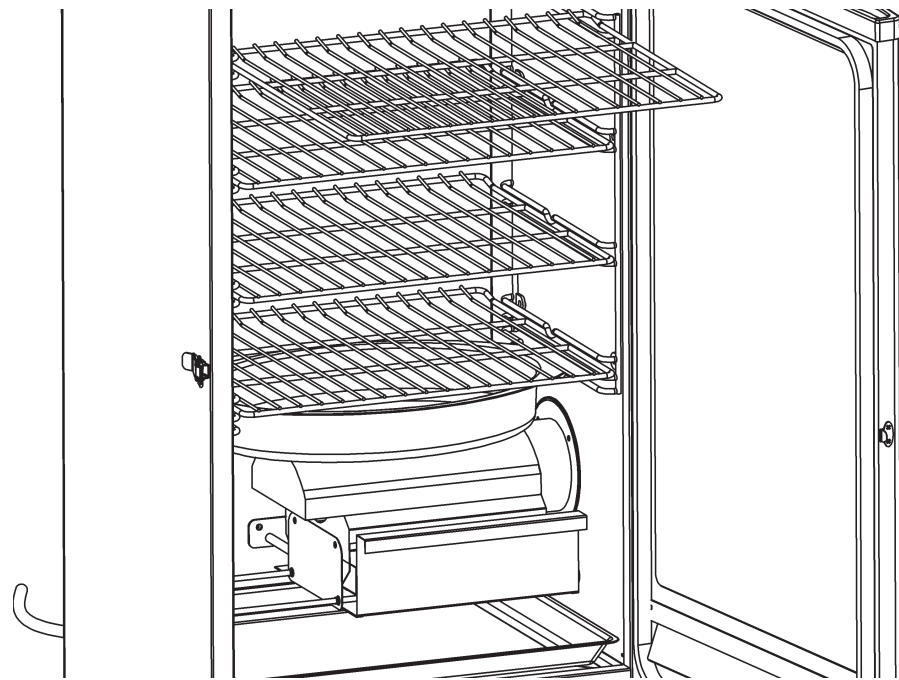

Step 7
Slide cooking racks onto guides inside smoker.

HOW TO USE WOOD CHIP LOADER

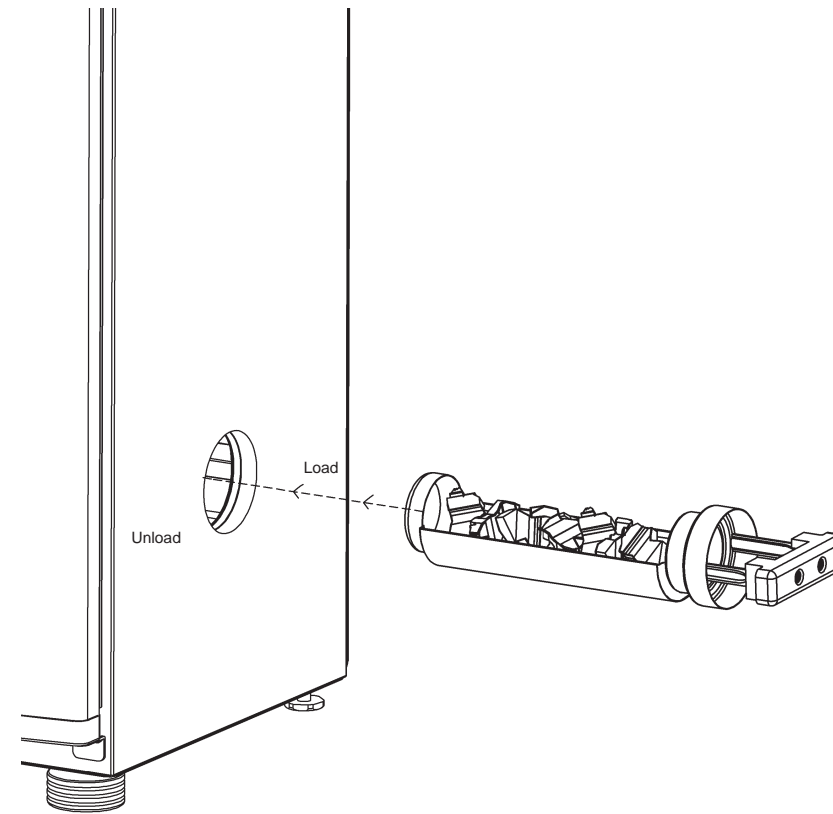

Pre-soak wood chips for at least 30 minutes.

When smoker reaches desired temperature place 1 cup of wood chips in wood chip loader.

Never use more than 1 cup of wood chips at a time.

Insert wood chip loader into smoker. Wood chips should be level with top rim of wood chip loader.

Turn handle to "Unload" mark on smoker. Wood will drop onto wood chip holder. Turn handle to "Load" and leave wood chip loader in place inside smoker.

Check wood chip holder periodically to see if wood has burned down by removing wood chip loader and looking into smoker through hole. Add more chips as needed.

Wood chip loader must be pulled out completely from smoker when checking wood chip level.

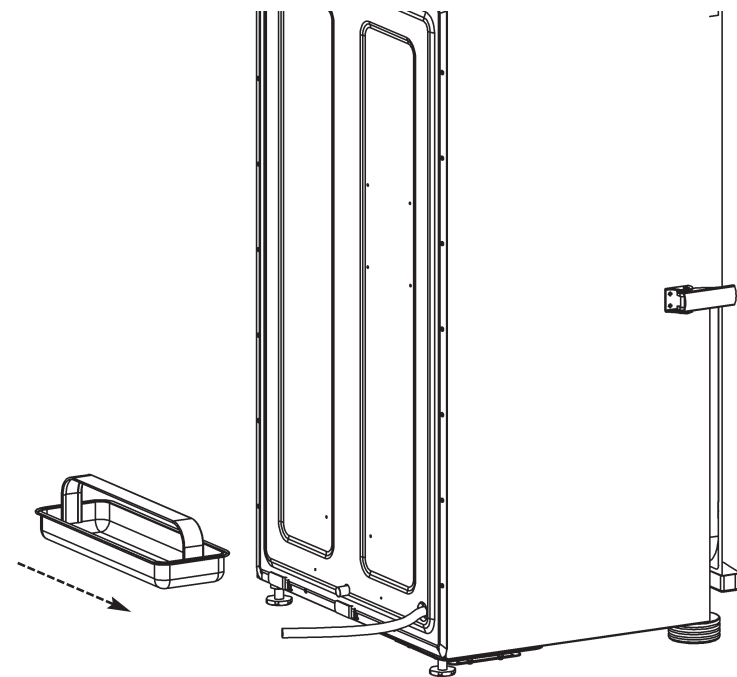

Step 8
Slide brackets on back of grease tray onto tabs on back of smoker body until grease tray stops.

Smoker is ready to use.

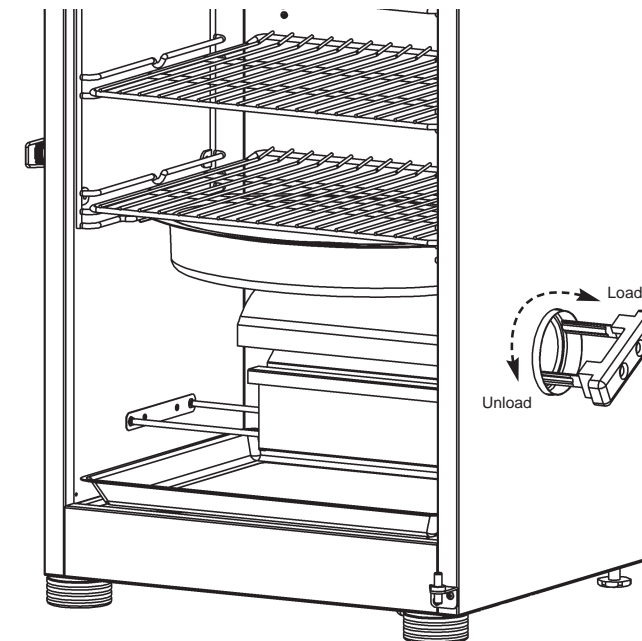

Adding more wood during smoking process:

Caution: Keep smoker door closed when adding wood chips.

Note: Wood chip loader will be HOT even if handle is not.

To add wood, turn handle to "Load" mark on smoker.

Pull wood chip loader from smoker.

Place wood chips in wood chip loader and re-insert into smoker.

Turn handle to "Unload" mark on smoker. Wood will drop onto wood chip holder.

Temperature may spike briefly after wood is added. It will stabilize after a short time. Do not adjust.

CAUTION

When door is opened a flare up may occur. Should wood chips flare up, immediately close door, wait for wood chips to burn down then open door again. Do not spray with water.